

Diaphragm Liquid Pumps

LP-1 Miniature Diaphragm Liquid Pumps are DC motor driven pumps for liquids. These small liquid pumps can be mounted in any position. A wide range of DC voltages are available to meet specific needs. The compact size of these small diaphragm liquid pumps makes these suitable for Medical, Laboratory & Consumer products.

FEATURES

- ✓ Long Life
- ✓ Small & Compact
- ✓ Self Priming
- ✓ Dry Running
- ✓ Chemical Resistance
- ✓ Maintenance-Free



LP-1A

LP-1B

LP-1C

LP-1 Miniature Diaphragm Liquid Pumps

Model	Flow (mL/min)	Pressure (PSI)	Voltage (DC)	Power (mA)	Weight (g)	Dimensions (mm)
LP-1A	500	40.0	6/12	1,200/1,000	65	60x30 Ø
LP-1B	900	20.0	6/12/24	1,200/600/350	65	60x30 Ø
LP-1C	2,000	30.0	12	800	108	75x36 Ø

LP-1A Liquid Pump



TECHNICAL DATA

Flow (mL/min): 500

Pressure (PSI): 40.0

Voltage (DC): 6/12

Power (mA): 1,200/1,000

Weight (g): 65

Dimensions (mm): 60x30 Ø

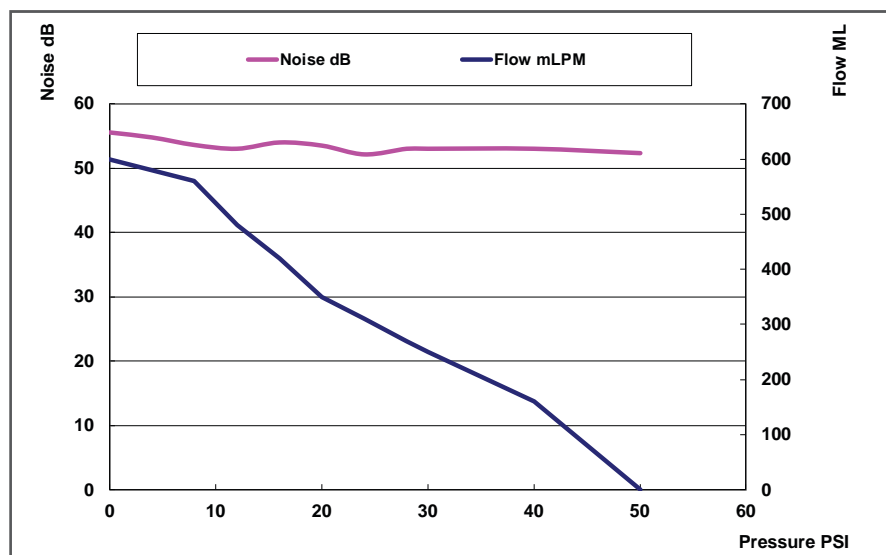
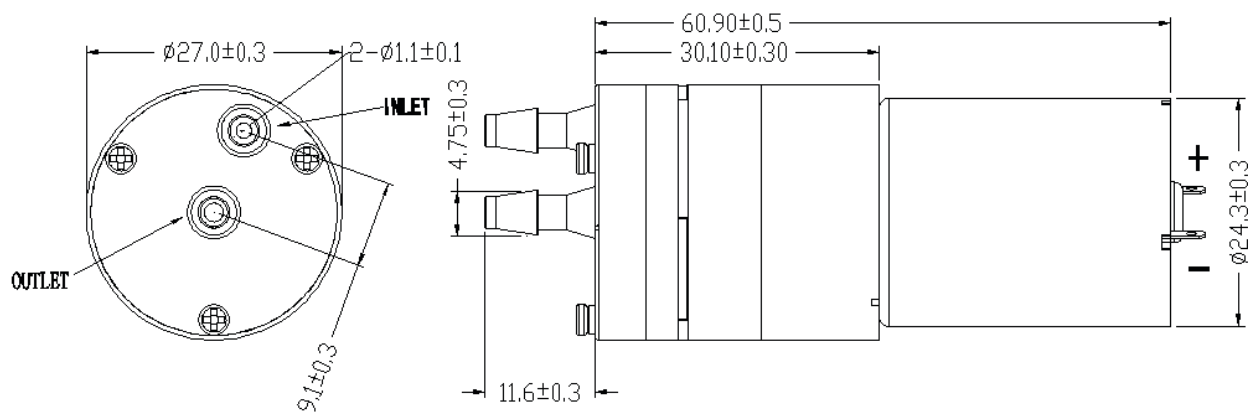

LP-1B Liquid Pump



TECHNICAL DATA

- Flow (mL/min): 900
- Pressure (PSI): 20.0
- Voltage (DC): 6/12/24
- Power (mA): 1,200/600/350
- Weight (g): 65
- Dimensions (mm): 60x30 Ø

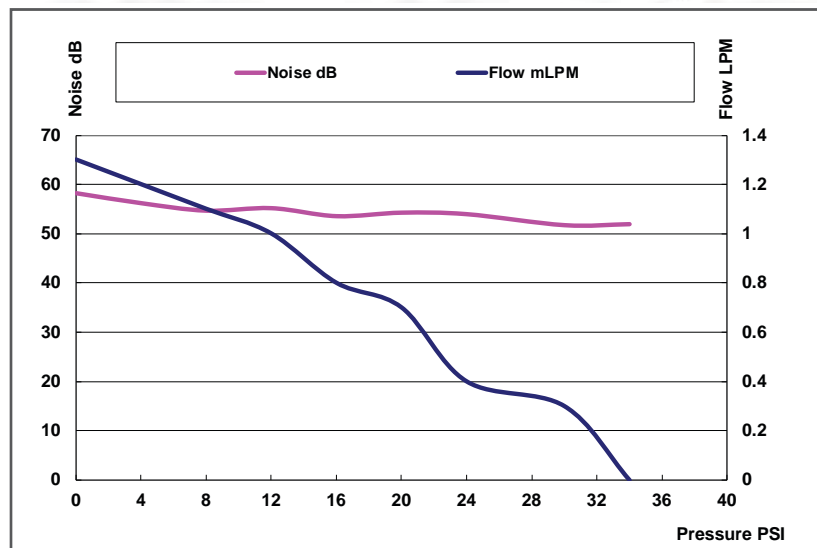
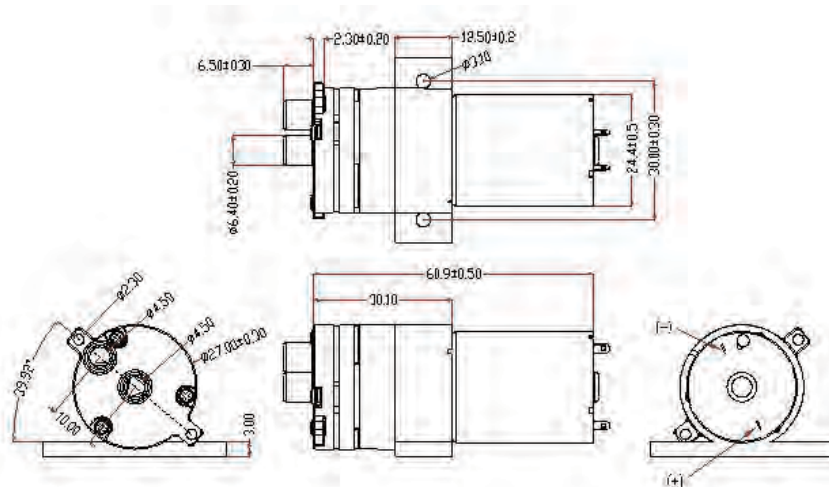

LP-1C Liquid Pump



TECHNICAL DATA

- Flow (mL/min): 2,000
- Pressure (PSI): 30.0
- Voltage (DC): 12
- Power (mA): 800
- Weight (g): 108
- Dimensions (mm): 75x36 Ø

